



(11) **EP 2 771 640 B1**

(12) **EUROPEAN PATENT SPECIFICATION**

(45) Date of publication and mention of the grant of the patent:  
**20.01.2021 Bulletin 2021/03**

(51) Int Cl.:  
**G01B 5/00** <sup>(2006.01)</sup> **G01N 3/08** <sup>(2006.01)</sup>  
**G01N 33/15** <sup>(2006.01)</sup> **B65G 47/04** <sup>(2006.01)</sup>

(21) Application number: **12794499.9**

(86) International application number:  
**PCT/IB2012/055735**

(22) Date of filing: **19.10.2012**

(87) International publication number:  
**WO 2013/061223 (02.05.2013 Gazette 2013/18)**

(54) **TABLET TESTING DEVICE**

TABLETTEN-TESTVORRICHTUNG

DISPOSITIF D'ESSAI DE TABLETTE

(84) Designated Contracting States:  
**AL AT BE BG CH CY CZ DE DK EE ES FI FR GB GR HR HU IE IS IT LI LT LU LV MC MK MT NL NO PL PT RO RS SE SI SK SM TR**

(30) Priority: **25.10.2011 US 201161550951 P**  
**25.10.2011 EP 11186470**

(43) Date of publication of application:  
**03.09.2014 Bulletin 2014/36**

(73) Proprietor: **SOTAX AG**  
**3600 Thun (CH)**

(72) Inventors:  
• **FORCELLA, Bruno**  
**CH-3612 Steffisburg (CH)**  
• **JUNOD, François**  
**CH-3303 Jegenstorf (CH)**

(74) Representative: **Patentbüro Paul Rosenich AG**  
**BGZ**  
**9497 Triesenberg (LI)**

(56) References cited:  
**EP-A1- 1 361 418** **EP-A1- 1 361 418**  
**EP-A2- 0 895 069** **EP-A2- 0 895 069**  
**WO-A1-89/07083** **WO-A1-89/07083**  
**WO-A1-2011/035818** **WO-A1-2011/035818**  
**DE-A1- 4 241 985** **DE-A1- 4 241 985**  
**DE-A1- 19 744 227** **DE-A1- 19 744 227**  
**DE-A1-102004 059 976** **DE-A1-102004 059 976**  
**DE-A1-102007 054 908** **DE-A1-102007 054 908**  
**DE-U1-202008 003 673** **DE-U1-202008 003 673**  
**JP-A- 2001 095 897** **JP-A- 2001 095 897**  
**US-A- 4 472 960** **US-A- 4 472 960**  
**US-A1- 2004 149 100** **US-A1- 2004 149 100**

**EP 2 771 640 B1**

Note: Within nine months of the publication of the mention of the grant of the European patent in the European Patent Bulletin, any person may give notice to the European Patent Office of opposition to that patent, in accordance with the Implementing Regulations. Notice of opposition shall not be deemed to have been filed until the opposition fee has been paid. (Art. 99(1) European Patent Convention).

## Description

**[0001]** The invention relates to a tablet testing device for testing tablets as defined in independent claim 1. Further aspects of the device are set out in dependent claims 2 to 9.

**[0002]** The invention further relates to methods of testing tablets in said tablet testing device as set out in independent claims 10 and 13. Further aspects of the methods are set out in dependent claims 11, 12, 14 and 15.

**[0003]** Such tablet testing devices are used in research and industry in order to meet the very high quality requirements, above all in the pharmaceutical sector. These devices are manually operated, semi- or fully automatic. They measure, for example, the weight, thickness, diameter, length and width as well as the hardness, that is, the breaking strength and breaking behaviour of tablets, using mechanical, electronic, optical, chemical or acoustic methods. As tablets come in a wide variety of shapes, the optimum and secure positioning of a tablet relative to a measuring device in the relevant method poses a great challenge to the developers and users of such tablet testing devices, particularly if on one tablet testing station various test procedures are implemented that require different positioning of the tablet.

**[0004]** From DE 102004036777 A1 a device for testing the breaking strength of oblong tablets with a horizontal transporting belt is known. It has a stationary breaking surface acting as a stop for oblong tablets on one side of the transporting belt, and on the other side of the transport belt, another breaking surface that is movable and is connected to an actuating and measuring device. It aligns the oblong tablets by two adjacently arranged rollers rotating in opposite directions.

**[0005]** On the one hand, a drawback of this known solution is the relatively elaborate, space-consuming and maintenance-intensive design with two separate motors and the roller as such, and, on the other hand, the fact that, particularly for small tablets and tablets of certain shapes, this tablet testing device cannot be used.

**[0006]** Known from DE 102008035830 A1 is a tablet testing device for carrying out a hardness test, and length, width and height measurement of test specimens. It includes a pressure measuring container, a pressure plate, a stop and a laser measuring device, in which the stop, push bars connected to a pusher and a shaft for moving guide clamps are arranged on a base plate. Guide clamps are described to have depression-like openings with a recess for receiving and positioning a tablet, as well as a measuring space. Provided on the base plate is a table surface for the tablet which can be moved in the direction of the stop. A pressure measuring sensor is connected to the slide and the pressure plate.

**[0007]** This solution is not only complex and expensive like the solution in DE 102004036777 A1, but is not suitable for all conceivable forms of tablet, nor for all forms of feeding-in of the tablets.

**[0008]** From the DE 102004059976 A1 a further device

with a testing station for testing the breaking strength of tablets is known, comprising several measuring stations for carrying out various testing methods on a tablet. A tablet is introduced into a breaking strength measurement station by means of a transport rake. In the transporting direction of the transport rake behind the breaking strength measurement station a pivotable abutment flap is provided for receiving the tablet in the breaking strength measurement station. After the breaking strength measurement, the abutment flap is pivoted away and the broken tablet is pushed out of the measurement station.

**[0009]** With this solution the clearances in the transport rake determine the orientation of the tablet, which cannot be turned from one orientation into another. Moreover, this solution requires that the dimensions of the tablet be known, rendering this tablet testing device only feasible for certain tablets.

**[0010]** From the DE 202008003673 U1 a device for orientating of objects, in particular tablets, for the purpose of carrying out measurements is known. A turnable roll and a flap pivotable with respect to this roll are provided as supporting points for the tablet. The orientation of the tablet is achieved by the turnable roll.

**[0011]** The complex arrangement of this solution is a great disadvantage, since two separate drives have to be provided for roll and flap. These drives must be controllable independently from each other. In addition, the gap between the roll and the flap determines the minimal size the tablet must have, and this narrows the range of use of this device.

**[0012]** From the US 4472960 A an apparatus for testing properties of a pharmaceutical solid is known, said apparatus comprising means for supplying the solid, for instance a pill or tablet, to a rotary drum rotatable in a vertical plane and having at the outer periphery recesses for holding said solid. When rotating said drum the recesses pass through a segment with an additional outer guiding means that prohibits the solids to fall out of the recesses until said recesses arrive at a lowermost position during the rotation of the drum. In this lowermost position the pills or tablets fall out of the recesses and reach in consecutive order means for performing at least one nondestructive test and means for performing a destructive test. When falling out of the recesses the pharmaceutical solids lose any orientation that the recesses might have imposed on them and their orientation for the following tests is not defined.

**[0013]** A device for cutting tablets is also known from the JP 2001095897 A.

**[0014]** The object of the invention is therefore to make available a tablet testing device for the testing of tablets which overcomes the aforesaid disadvantages, that is, being smaller, cheaper, simpler and, in particular being usable for tablets of every shape in different test procedures and in different test equipment. A further object of the present invention is a method for the testing of tablets with such tablet testing device achieving the same advantages.

**[0015]** The first object may be achieved through the features of independent claim 1, and the further object may be achieved through the features of independent claims 10 and 13. Advantageous further embodiments are set out in the figures and in the dependent claims.

**[0016]** In accordance with the invention, the first embodiment of the tablet testing device includes at least one movable receiving structure for the tablets and at least one curved surface interacting with the movable surface and arranged at a defined distance from the outer edge of the movable receiving structure facing it. This first embodiment is characterised by at least one movable positioning surface for receiving the tablets and allowing the tablets to slide on the positioning surface, and by the curved surface formed along the arc of the pivoting movement of the positioning surface. Here - with the further surface being a curved positioning surface formed along the radius of the pivoting movement of the first surface - and for all other embodiments of the invention, the design of the means for positioning tablets is in the form of two interacting surfaces, with at least one of them being pivotable, and is associated with great economic and technical improvements: this relatively simple design is cost-effective and maintenance-friendly. This allows process-adapted positioning of every conceivable elongated tablet within the shortest time and is in principle imaginable within every testing process and with every manner of manual or automatic feeding.

**[0017]** As already indicated above, an embodiment of the invention is characterised by a pivotable flap as at least one movable positioning surface. Preferred, at least one means is provided on the curved surface to at least briefly interrupt the pivoting movement of the movable surface or to disturb the sliding movement of a tablet, said means for instance being an interference contour. As an alternative, a ridge and/or a recess in the positioning surface could be provided to at least briefly interrupt the pivoting movement of the movable surface or to disturb the sliding movement of a tablet.

**[0018]** The same advantages as mentioned above can be achieved with an embodiment not covered by the present invention that is characterised by at least one movable positioning surface for receiving the tablets and allowing the tablets to slide on the positioning surface, and by at least one further plane positioning surface moving together with the movable positioning surface and protruding in a defined angle from the movable positioning surface on its edge opposite the axis of the pivoting movement.

**[0019]** According to said embodiment not forming part of the claimed invention, the plane positioning surface protrudes from the movable positioning surface in an angle between 45 and 135°, preferably in a right angle. In addition or as an alternative to the pivoting movement, the movable flap could be displaceable in the planar direction. Another embodiment of the invention is characterised in that a rotation axis of the movable flap is arranged at a predefined angle  $\alpha$  less than or greater than

90°, preferably around 80° or around 100°, to a fixed surface on the breaking surface.

**[0020]** Any of the tablet testing devices described above could be further developed by a further positioning surface being formed by the fixed breaking surface, in relation to which the rotation axis of the moveable positioning surface is arranged at an angle  $\alpha$ . Said further positioning surface can even be formed on a moveable breaking surface. The latter embodiment is of particular advantage in case that the movable breaking surface forms parts of the measuring device.

**[0021]** Any one of the preceding embodiments of the invention can show at least one redirecting contour for redirecting the sliding movement of a tablet on the movable positioning surface.

**[0022]** Finally, also the last of the basic embodiments has the above-explained advantages, said embodiment not forming part of the present invention and being characterised by at least one movable positioning flap for receiving the tablets and allowing the tablets to slide on the flap and by a further positioning surface in form of a further flap which is pivotable and/or can be displaced in the planar direction. In this last embodiment not covered by the claimed invention the surface which interacts with the movable positioning surface, preferably flap, in order to orientate the tablet, is designed as a second flap which is in parallel to and pivotable against the first flap, and preferably, in order to have the same positioning effect as the flap which is only pivotable, is arranged to move longitudinally relative thereto. With an embodiment of this type it is also possible to realign tablets, even those with a position varying greatly from the ideal position. However the embodiment with two flaps has the design and therefore economic disadvantage that it requires two separate motors. A procedural drawback is that a tablet can unintentionally become stuck between the two surfaces. Also it is easily possible to lose the tablet to the waste bin before completion of all measuring procedures if it unintentionally slips between the two flaps as a result of an unfortunate positioning angle. The economically preferred solution is therefore the one with one flap.

**[0023]** The tablet testing as described above, which does not form part of the present invention, can be further characterised in that the positioning surface is arranged in parallel to the moveable positioning surface of a flap and can be pivoted and longitudinally displaced in relation thereto. For each and every of the inventive embodiments an additional advantage can be achieved by at least one vibration means being provided and adapted to vibrate at least the movable positioning surface.

**[0024]** For the sake of simplicity, but certainly not restricted to these processing stages, the arrangement, in accordance with the invention, of a tablet testing device in a tablet testing station which tests the length, width and hardness, that is, the breaking strength or breaking behaviour shall be described. In such a tablet testing station advantages according to the invention become clearest to a person skilled in the art, as different positioning

of the tablets during the various processing stages with tablet testing devices from the prior art is not achieved adequately, or is achievable only with considerable effort. Above all, it is difficult to reposition the tablet before and between the measuring procedures for preparing the breaking strength test, during which the tablet is usually destroyed. If the tablet is not brought into the correct position for each measuring or testing procedure, often due to its special shape, the measuring or test result is inadequate.

**[0025]** The tablet is manually or preferably automatically supplied to the tablet testing station in accordance with the invention, and lands on a random point on a movable positioning plane, preferably designed as a type of flap. Though a movement of the positioning plane is it initially brought into the ideal position for measurement of the length and width. After measurement, the tablet is newly orientated through a pivoting movement of the positioning plane, as, irrespective of how it was lying before, for the hardness test it must be brought into precise alignment between two pressure surfaces, at least one of which is generally provided with the measuring device which implements the hardness test. For this test procedure a longitudinal orientation of the tablet is normally required. Finally, the tablet, either intact or broken, is removed from the testing process.

**[0026]** For the advantageous execution of the above-outlined process the process steps are characterised in that the tablet is initially supplied to the test station, placed on the positioning surface and, if necessary, orientated a first time by the movable positioning surface, is then moved by the moveable breaking surface so that it is then aligned in parallel to the fixed breaking surface, in that subsequently by means of measuring devices width and/or length and/or thickness measurements are carried out on the tablet, in that by means of a pivoting movement of the movable positioning surface, possibly interrupted by the interference contour or repositioned by the repositioning device is then brought into another orientation and in that a longitudinal measurement of the tablet may possibly then be carried out, after which a breaking strength test or breaking behaviour test is carried out and the tablet is then removed from the testing station by pivoting at least the movable positioning surface.

Further preferred embodiments are characterized in that the movable positioning surface is pivoted from a maximally horizontal position into a position above the horizontal orientation of the movable positioning surface, whereby the orientation of the tablet is turned. Embodiments not covered by the present invention consist of the combination of the features that the movable positioning surface in cooperation with the positioning surface at the further flap is pivoted into a V-position into a vertical position by a pivoting movement of the positioning surfaces and relative to each other. Still another embodiment provides the step of vibrating at least the movable positioning surface by the vibration means for positioning of the tablet.

**[0027]** The invention shall be described in more detail below symbolically and exemplarily with the aid of the figures. The figures are described in summary and overall. The same reference numbers denote the same components throughout. The list of reference numbers also forms part of the disclosure.

**[0028]** In the drawings:

- 5  
10  
15  
20  
25  
30  
35  
40  
45  
50  
55
- Fig. 1 - shows a schematic view of a first example of embodiment of a tablet testing device in accordance with the invention,
  - Fig. 2 - shows a schematic view of an example of a tablet testing device in accordance with the invention with a breaking surface/a measuring device,
  - Fig. 3 - shows a schematic view of an example of embodiment of a tablet testing device with an interference contour on the positioning surface,
  - Fig. 4 - shows a schematic view of an example of embodiment of a tablet testing device in accordance with the invention with a redirecting element on the positioning surface
  - Fig. 5 - shows a schematic view of an example of embodiment of a tablet testing device in accordance with the invention with a slightly lowered positioning surface,
  - Fig. 6 - shows a schematic view of an example of embodiment of a tablet testing device in accordance with the invention with an angled positioning surface,
  - Fig. 7 - shows a schematic view of an example of embodiment of a tablet testing device not covered by the present invention with two flaps that are pivotable and movable on the planar direction,
  - Fig. 8a - shows a schematic view of an example of embodiment of a tablet testing device not covered by the present invention with an additional positioning surface protruding from the movable flap and pivoting together with said flap, with the flap in horizontal position,
  - Fig. 8b - shows a schematic view of the embodiment of Fig. 8a with the flap pivoted below the horizontal position,
  - Fig. 9 - shows a schematic view of an example of embodiment of a tablet testing device not covered by the present invention with an additional positioning surface protruding from the movable flap and having a redirecting or interference contour,
  - Fig. 10 - shows a schematic view of an example of embodiment of a tablet testing device not covered by the present invention with a pivoting axis being oblique with respect to the further positioning surface pivoting together with the flap, and
  - Fig. 11 - shows schematic view of an example of em-

bodiment of a tablet testing device in accordance with the invention with a lift.

**[0029]** The arrangement set out in figure 1 depicts part of a testing station of a table testing device with relevance to the invention. Here, a tablet 12 lies on a first positioning surface, designed as a flap 11, that is shown pivoted relative to a second positioning surface shown here as curved surface 14. The curved surface 14 is provided along the rotation line (arc) R1 of the outer edge of the flap 11 facing it so that the predetermined, preferably as small a gap as possible, between the two remains the same during the pivoting movement of the flap 11. Perpendicularly to the axis of rotation 19 of the flap and to the curved surface 14 a further positioning surface is to be imagined, which in this case is designed as a fixed breaking surface 15 and may also interact with the flap 11 and/or with the curved surface 14 in order to position the tablet 12. It may be designed, for example, as a mounting for a rotation axle 19, preferably in the form of a rotating shaft, or as a wall of the actuator driving the rotating shaft. In each case, during a testing procedure the tablet 12 is pushed by a movable breaking surface 17 (shown in figure 2) against this fixed breaking surface 15.

**[0030]** Figure 1 depicts how when the flap 11 is pivoted, the tablet 12, obeying the laws of gravity, slides down towards the curved surface 14 and comes to rest against it, in a manner dependent on its own weight and on the pivoting movement. The rotation movement of the flap 11 is adapted to the shape of the tablet 12 and to the required end position. It may range from simple vibration to a large pivoting movement to below the curved surface 14, the latter pivoting movement removing the test specimen from the tablet testing station.

**[0031]** In principle figure 2 depicts the same arrangement as in figure 1, but with one breaking surface 17 as the positioning surface, which can preferably be moved over the shown arrangement. For testing purposes it pushes the test specimen 12 located on the flap 11 up to the fixed breaking surface 15, where the actual pressure test takes place. The tablet 12 is pressed by the breaking surface 17 against the fixed breaking surface 15 at a predefined force, or a predefined time, or until it breaks. The breaking surface 17 then returns to its initial position shown in figure 2 and the flap it pivoted downwards until the tablet 12, either intact or broken, falls out of the tablet testing station through gravitational force.

**[0032]** Figure 3 depicts a variant of the arrangement in figure 1. On the curved surface 14 there is an interference contour, that is, the curved surface 14 is not designed exactly along the line of rotation (arc) R1 of the facing outer edge of the flap 11, but has a ridge or recess there so that the predetermined, preferably as small a gap as possible between the two, may vary during the pivoting movement of the flap 11; or so that a tablet 12 sliding along the curved surface 14 is subject to increased sliding resistance. As a result of this, on the one hand

the desired lateral displacement or tilting of the tablet depicts be brought about, or, on the other hand, through its special design of the curved surface 14 the result may be achieved that the rotational movement of the flap 11 and/or sliding movement of the tablet 12 is not linear, but is interrupted. Through interrupting the pivoting and/or sliding movement, a slight vibration of the flap 11 and/or the tablet is produced and in turn brings about a repositioning of the tablet 12.

**[0033]** Figure 4 depicts a preferred embodiment of the flap 11 also with a redirecting element 16 similar to an interference contour. Here, when the flap 11 is pivoted upwards, whereby the outer edge preferably projects over the curved surface 14, the tablet is initially pressed against the redirecting element 16 through gravity, as shown in figure 4, in order when the flap 11 is then pivoted downwards to then also be positioned through gravity in the required parallel position against the curved surface.

**[0034]** Figure 5 depicts how, after alignment of the tablet (figures 1 - 4) the flap is not moved completely upwards into a horizontal position in order to produce a lateral guide A1 for the tablet through the curved surface 15. In this way turning of the tablet may be prevented for the subsequent test procedure.

**[0035]** Figure 6 also depicts a preferred embodiment of the arrangement in accordance with the invention. Here the axis of rotation 19 of the flap 11, preferably in the form of a rotating shaft, is pivotable. The curved surface 14 is designed accordingly along the changed line of rotation. In this way the rotation axis 19 of the flap 11 may be angled so that again through the force of gravity the tablet 12 is forced into a required position through the oblique positioning of the flap 11 in relation to the curved surface 14. It is possible to predefine the angle  $\alpha$  of rotation axis 19/ fixed breaking surface 15 in accordance with the shape and the weight of the tablet. A desirable tablet position in most cases is as close to the fixed breaking surface as possible, whereby subsequent, time-consuming and positioning-endangering movement by the moveable breaking surface is dispensed with, and the testing procedure may take place immediately.

**[0036]** Figure 7 depicts an arrangement not covered by the claimed invention with a flap 11 and a further positioning surface, here in the form of flap 11a which are arranged in parallel to each other and pivot in relation to each other in a known manner. In an embodiment its two actuators (not visible here) are newly designed so that the flaps 11 and 11a are not only pivotable, but may also be moved on the planar direction, that is, along the axis of rotation 19 and 19a, respectively. In this way, the two flaps 11 and 11a may be displaced with regard to each other. Through gravity the position of the tablet may be changed through each of the two movements of the positioning surfaces. If both flaps 11 and 11a are pivoted downward until they form a V-shape with regard to each other, the tablet 12 undergoes longitudinal orientation in relation to the two breaking surfaces 15 and 17 (which

is not shown here), i.e. the movable breaking surface. If the flaps 11 and 11a are in the same plane and longitudinally displaced with regard to each other by any suitable displacement mechanism, due to gravity the tablet is transversely orientated via the friction, in other words it is positioned in parallel to the breaking surfaces 15 and 17.

**[0037]** Figures 8a and 8b depict schematic views of a further example not covered by the present invention in different positions. Again the tablet 12 lies on a first positioning surface, designed as a flap 11. On the edge of the flap 11 opposite the pivoting axis 19 a further and preferably plane positioning surface 11b is provided, which surface 11b moves together with the flap 11 and protrudes in a defined angle from the movable positioning surface of flap 11. Preferably the positioning surface 11b is integral with flap 11. The angle between the first positioning surface on flap 11 and the further positioning surface 11b is in a range between 45 and 135°, preferably 90°.

**[0038]** Figure 8b depicts the situation when the movable flap 11 is pivoted downwards so that the tablet 12, obeying the laws of gravity, slides down towards the further positioning surface 11b and comes to rest against it depending on its own weight and the pivoting movement. The rotation movement of the flap 11 is adapted again to the shape of the tablet 12 and the required end position, as explained in detail in connection with Figure 1. The movement of flap 11 may possibly be achieved by a vibration means 22, for example a vibration motor, as indicated schematically in Fig. 11.

**[0039]** Figure 9 depicts an enhanced embodiment of a device not covered by the present invention according to Figures 8a and 8b. Again and similar to the embodiment of Figure 4, a redirecting element 16 similar to an interference contour is provided on the side of flap 11 near the pivoting axis 19. In the shown position, with the flap 11 pivoted upwards, the tablet is initially pressed against the redirecting element 16 through gravity. Then, after the flap 11 is pivoted downwards the tablet 12 is directed into the required parallel position against the further positioning surface 11b on flap 11, again through gravity.

**[0040]** As can be gathered from Figure 10, also with an embodiment not covered by the claimed invention as shown in Figures 8a and 8b, with a positioning surface 11b movable together with flap 11, the pivoting axis 19 of this flap 11 may preferably be pivotable or be fixed in an oblique angle with respect to a direction perpendicular to the fixed breaking surface 15. A pivoting axis 19 oriented like that brings flap 11 and further positioning surface 11b in a respective oblique position which forces the tablet 12 into the required position by the effect of gravity. Here again it is possible to predefine the angle  $\alpha$  between the rotation axis 19 and the fixed breaking surface 15 in accordance with the shape and the weight of the tablet.

**[0041]** Figure 11 depicts a preferred embodiment in

accordance with the invention in which the further positioning surface, which interacts with the first positioning surface for the purpose of orientation, is designed as a height-adjustable unit, preferably a lift 20. This lift raises the entire device with the first movable positioning surface 11 or with the positioning surfaces 11 and 11a (not shown here) together with their actuator 21 upwards in order to acquire a tablet from a supply device (not shown). In accordance with the invention it moves as closely as possible to the supply device in order to prevent uncontrolled placing of the tablet on the flap 11. For the subsequent processing stages the lift descends in order, for example, to give the measuring devices 13, possibly integrated with the movable breaking surface 17, and 13a space. The lift shown here is described in more detail in a further application, which is to apply as an integral part of the present application.

#### List of reference labels

##### [0042]

11, 11a	Flap/positioning surface
12	Tablet
13, 13a	Measuring device
14	Curved surface
15	Fixed breaking surface/fixed surface
16	Redirecting element (interference contour)
17	Displaceable/movable breaking surface and/or further positioning surface
18	Interference contour
19, 19a	Axis of rotation
20	Lift
21	Actuator
22	Vibration means
R1	Rotation line
$\alpha$	Angle of rotation axis 19 / fixed breaking surface 15
A1	Guiding on curved surface

#### Claims

1. A tablet testing device for testing tablets with at least one tablet testing station comprising means suitable for carrying out at least one test procedure on a tablet (12), and at least one means for receiving and crushing the tablet, said at least one means for receiving and crushing the tablet (12) comprising a movable breaking surface (17) and a fixed breaking surface (15), the tablet (12) being received and crushed between said movable breaking surface (17) and said fixed breaking surface (15), the tablet (12) being pressed by the movable breaking surface (17) against the fixed breaking surface (15), and at least one means of positioning the tablet relative to the tablet testing station and relative to the breaking surfaces (17,15) in accordance with the at least one test

- procedure, **characterised in that** the means of positioning the tablet (12) is formed of at least one movable positioning surface on the upper side of a movable flap (11) having an outer edge, and at least one further surface, which, for the purpose of positioning the tablet (12) through the effect of gravity on the tablet (12), interacts with the movable flap (11) and its outer edge, whereby the movable flap (11) is pivotable around an axis lying on the opposite side of its outer edge and the at least one further surface is formed as a curved positioning surface (14) provided along the rotation line (R1) of the outer edge of the flap (11) facing it and said at least one further surface is at a defined distance from the outer edge of the flap (11) so that the outer edge of said flap (11) is configured to rotate along said curved positioning surface (14) downwards or upwards, thereby allowing a tablet, which eventually lies on said movable positioning surface to slide on said movable positioning surface under gravity towards said curved positioning surface (14).
2. The tablet testing device according claim 1, **characterised in that** on the curved positioning surface (14) at least an interference contour (18) is provided in order to at least briefly interrupt the pivoting movement of the flap (11) or to disturb the sliding movement of a tablet (12).
  3. The tablet testing device according to claim 2, **characterised in that** said interference contour (18) is formed by a ridge and/or a recess in the curved positioning surface (14).
  4. The tablet testing device according to any of claims 1 to 3, **characterised in that** a rotation axis (19) of the movable flap (11) is arranged at a predefined angle ( $\alpha$ ) to the fixed breaking surface.
  5. The tablet testing device according to claim 4, **characterised in that** the angle ( $\alpha$ ) is less than or greater than  $90^\circ$ , preferably around  $80^\circ$  or around  $100^\circ$ .
  6. The tablet testing device according to any of claims 1 to 5, **characterised in that** a further positioning surface is formed on the moveable breaking surface (17).
  7. The tablet testing device according to claim 6, **characterised in that** the movable measuring and/or breaking surface (17) forms parts of a measuring device (13).
  8. The tablet testing device according to any one of the preceding claims, **characterised in that** on the flap (11) at least one redirecting contour (16) for redirecting the sliding movement of a tablet (12) is provided.
  9. The tablet testing device according to any of the preceding claims, **characterised in that** at least one vibration means (22) is provided and adapted to vibrate at least the movable flap (11).
  10. A method of testing tablets with a tablet testing device according to any one of the preceding claims, **characterised in that** the tablet (12) is initially supplied to the test station, placed on the positioning surface (11) and, if necessary, orientated a first time by the positioning surface (11), is then moved by the moveable breaking surface (17) so that it is then aligned in parallel to the fixed breaking surface (15), **in that** subsequently by means of measuring devices (13, 13a) width and/or length and/or thickness measurements are carried out on the tablet (12), **in that** by means of a pivoting movement of the movable flap (11), possibly interrupted by the interference contour (18) or repositioned by a repositioning device (16) is then brought into another orientation and **in that** a longitudinal measurement of the tablet (12) may possibly then be carried out, after which a breaking strength test or breaking behaviour test is carried out by crashing the tablet and the tablet (12) is then removed from the testing station by pivoting at least the movable flap (11).
  11. A method according to claim 10, **characterised in that** the movable flap (11) is pivoted from a maximally horizontal position into a position above the horizontal orientation of the movable flap (11), whereby the orientation of the tablet (12) is turned.
  12. A method according to any of claims 10 to 11, **characterised in that** at least the movable flap (11) is vibrated by the vibration means (22) for positioning of the tablet (12).
  13. A method for testing tablets with a tablet testing device according to any one of claims 1 to 9 comprising the steps of:
    - supplying a tablet (12) to a test station;
    - placing the tablet on a positioning surface of a moveable flap (11) in the test station;
    - pivoting the movable flap (11) to selectively orient the tablet;
    - executing a breaking test on the tablet in order to crush it; and,
    - pivoting the movable (11) flap in order to remove the tablet (12) by gravity.
  14. A method for testing tablets as claimed in claim 13, **further comprising** the step of: pivoting the flap (11) from a horizontal position to an above-horizontal position so as to turn the tablet.
  15. A method for testing tablets as claimed in claim 13,

further comprising the step of: vibrating the movable flap (11) to selectively position a tablet (12).

### Patentansprüche

1. Tablettenprüfgerät zum Prüfen von Tabletten mit mindestens einer Tablettenprüfstation, umfassend geeignete Vorrichtungen zum Ausführen von mindestens einem Prüfverfahren an einer Tablette (12), und mindestens eine Vorrichtung zum Aufnehmen und Zerdrücken der Tablette, wobei die mindestens eine Vorrichtung zum Aufnehmen und Zerdrücken der Tablette (12) eine bewegliche Zerkleinerungsfläche (17) und eine feststehende Zerkleinerungsfläche (15) umfasst, wobei die Tablette (12) zwischen der beweglichen Zerkleinerungsfläche (17) und der feststehenden Zerkleinerungsfläche (15) aufgenommen und zerdrückt wird und die Tablette (12) von der beweglichen Zerkleinerungsfläche (17) gegen die feststehende Zerkleinerungsfläche (15) gedrückt wird, und mindestens eine Vorrichtung zum Positionieren der Tablette in Bezug auf die Tablettenprüfstation und in Bezug auf die Zerkleinerungsflächen (17, 15) in Übereinstimmung mit dem mindestens einen Prüfverfahren, **dadurch gekennzeichnet, dass** die Vorrichtung zum Positionieren der Tablette (12) von mindestens einer beweglichen Positionierungsfläche auf der oberen Seite einer beweglichen Klappe (11) gebildet wird, die einen Außenrand aufweist, und mindestens einer weiteren Fläche, die zum Zwecke der Positionierung der Tablette (12) durch die Wirkung der Schwerkraft auf die Tablette (12) mit der beweglichen Klappe (11) und ihrem Außenrand interagiert, wodurch die bewegliche Klappe (11) um eine Achse schwenkbar ist, die auf der entgegengesetzten Seite ihres Außenrands liegt; und die mindestens eine weitere Fläche ist als eine gekrümmte Positionierungsfläche (14) ausgebildet, die entlang der Rotationslinie (R1) des Außenrands der Klappe (11) ihr gegenüber vorgesehen ist, und die mindestens eine weitere Fläche liegt in einem definierten Abstand zum Außenrand der Klappe (11), sodass der Außenrand der Klappe (11) so konfiguriert ist, dass er entlang der gekrümmten Positionierungsfläche (14) nach oben oder nach unten rotiert und damit ermöglicht, dass eine Tablette, die vielleicht auf der beweglichen Positionierungsfläche liegt, auf der beweglichen Positionierungsfläche unter Schwerkraft auf die gekrümmte Positionierungsfläche (14) zu gleitet.
2. Tablettenprüfgerät nach Anspruch 1, **dadurch gekennzeichnet, dass** auf der gekrümmten Positionierungsfläche (14) mindestens eine Störkontur (18) vorgesehen ist, um mindestens kurz die Schwenkbewegung der Klappe (11) zu unterbrechen oder die

Gleitbewegung einer Tablette (12) zu stören.

3. Tablettenprüfgerät nach Anspruch 2, **dadurch gekennzeichnet, dass** die Störkontur (18) von einem Grat in der gekrümmten Positionierungsfläche (14) gebildet wird.
4. Tablettenprüfgerät nach einem der Ansprüche 1 bis 3, **dadurch gekennzeichnet, dass** eine Rotationsachse (19) der beweglichen Klappe (11) in einem vorgegebenen Winkel ( $\alpha$ ) zur feststehenden Zerkleinerungsfläche angeordnet ist.
5. Tablettenprüfgerät nach Anspruch 4, **dadurch gekennzeichnet, dass** der Winkel ( $\alpha$ ) kleiner oder größer als  $90^\circ$ , vorzugsweise um  $80^\circ$  oder um  $100^\circ$ , ist.
6. Tablettenprüfgerät nach einem der Ansprüche 1 bis 5, **dadurch gekennzeichnet, dass** eine weitere Positionierungsfläche auf der beweglichen Zerkleinerungsfläche (17) ausgebildet ist.
7. Tablettenprüfgerät nach Anspruch 6, **dadurch gekennzeichnet, dass** die bewegliche Mess- und/oder Zerkleinerungsfläche (17) Teil eines Messgeräts (13) ist.
8. Tablettenprüfgerät nach einem der vorstehenden Ansprüche, **dadurch gekennzeichnet, dass** auf der Klappe (11) mindestens eine umleitende Kontur (16) zum Umleiten der Gleitbewegung einer Tablette (12) vorgesehen ist.
9. Tablettenprüfgerät nach einem der vorstehenden Ansprüche, **dadurch gekennzeichnet, dass** mindestens eine Vibrationsvorrichtung (22) vorgesehen und geeignet ist, um mindestens die bewegliche Klappe (11) zu vibrieren.
10. Verfahren zum Prüfen von Tabletten mit einem Tablettenprüfgerät nach einem der vorstehenden Ansprüche, **dadurch gekennzeichnet, dass** die Tablette (12) anfänglich an die Prüfstation geliefert wird, auf die Positionierungsfläche (11) platziert wird und nötigenfalls ein erstes Mal durch die Positionierungsfläche (11) ausgerichtet wird, dann durch die bewegliche Zerkleinerungsfläche (17) bewegt wird, um dann parallel zur feststehenden Zerkleinerungsfläche (15) ausgerichtet zu werden; dadurch, dass nachfolgend mithilfe von Messgeräten (13, 13a) Breiten- und/oder Längen- und/oder Dickenmessungen an der Tablette (12) ausgeführt werden; dadurch, dass mithilfe einer Schwenkbewegung der beweglichen Klappe (11), möglicherweise durch Störkontur (18) unterbrochen oder durch eine Umpositionierung (16) umpositioniert, die Tablette dann in eine andere Ausrichtung gebracht wird; und dadurch, dass eine Längsmessung der Tablette (12)



möglicherweise dann ausgeführt wird, wonach ein Zerkleinerungsstärketest oder ein Zerkleinerungsverhaltenstest durch Zerdrücken der Tablette ausgeführt wird, und die Tablette (12) dann durch mindestens Schwenken der beweglichen Klappe (11) aus der Prüfstation entfernt wird.

11. Verfahren nach Anspruch 10, **dadurch gekennzeichnet, dass** die bewegliche Klappe (11) aus einer maximal horizontalen Position in eine Position über der horizontalen Ausrichtung der beweglichen Klappe (11) geschwenkt wird, wodurch die Ausrichtung der Tablette (12) gedreht wird.

12. Verfahren nach einem der Ansprüche 10 bis 11, **dadurch gekennzeichnet, dass** mindestens die bewegliche Klappe (11) von der Vibrationsvorrichtung (22) zum Positionieren der Tablette (12) vibriert wird.

13. Verfahren zum Prüfen von Tabletten mit einem Tablettenprüfgerät nach einem der Ansprüche 1 bis 9, umfassend die folgenden Schritte:

Liefere einer Tablette (12) an eine Prüfstation; Platziere die Tablette auf eine Positionierungsfläche einer beweglichen Klappe (11) in der Prüfstation;

Schwenke die bewegliche Klappe (11), um selektiv die Tablette auszurichten;

Ausführe eine Zerkleinerungsprüfung an der Tablette, um sie zu zerdrücken; und

Schwenke die bewegliche (11) Klappe, um die Tablette (12) durch Schwerkraft zu entfernen.

14. Verfahren zum Prüfen von Tabletten wie in Anspruch 13 beansprucht, ferner umfassend folgenden Schritt: Schwenke die Klappe (11) aus einer horizontalen Position in eine Position über der horizontalen, um die Tablette zu drehen.

15. Verfahren zum Prüfen von Tabletten wie in Anspruch 13 beansprucht, ferner umfassend folgenden Schritt: Vibriere die bewegliche Klappe (11), um eine Tablette (12) selektiv zu positionieren.

## Revendications

1. Dispositif d'essai de comprimés destiné à tester des comprimés avec au moins une station d'essai de comprimés comprenant des moyens adaptés pour réaliser au moins une procédure d'essai sur un comprimé (12), et au moins un moyen de réception et de broyage, ledit au moins un moyen de réception et de broyage du comprimé (12) comprenant une surface de rupture mobile (17) et une surface de rupture fixe (15),

le comprimé (12) étant reçu et broyé entre ladite surface de rupture mobile (17) et ladite surface de rupture fixe (15), le comprimé (12) étant comprimé au moyen de la surface de rupture mobile (17) contre la surface de rupture fixe (15),

et au moins un moyen de positionnement du comprimé par rapport à la station d'essai de comprimés et par rapport aux surfaces de rupture (17, 15) conformément avec l'au moins une procédure d'essai, **caractérisé en ce que** des moyens de positionnement du comprimé (12) sont formés d'au moins une surface de positionnement mobile située sur le côté supérieur d'un volet mobile (11) comportant un bord externe, et au moins une surface supplémentaire, qui, dans le but de positionner le comprimé (12) par effet de gravité sur le comprimé (12), interagit avec le volet mobile (11) et son bord externe, moyennant quoi le volet mobile (11) peut pivoter autour d'un axe reposant sur le côté opposé de son bord externe et l'au moins une surface supplémentaire est formée en tant que surface de positionnement courbe (14) fournie le long de la ligne de rotation (R1) du bord externe du volet (11) lui faisant face et ladite au moins une surface supplémentaire se trouve à une distance définie du bord externe du volet (11) de sorte que le bord externe dudit volet (11) est conçu pour tourner le long de ladite surface de positionnement courbe (14) vers le bas ou vers le haut, permettant ainsi à un comprimé, qui repose éventuellement sur ladite surface de positionnement mobile de glisser sur ladite surface de positionnement mobile par gravité en direction de ladite surface de positionnement courbe (14).

2. Dispositif d'essai de comprimés selon la revendication 1, **caractérisé en ce que** sur la surface de positionnement courbe (14) au moins un contour d'interférence (18) est fourni de manière à au moins interrompre brièvement le mouvement de pivot du volet (11) ou pour perturber le mouvement de glisse d'un comprimé (12).

3. Dispositif d'essai de comprimés selon la revendication 2, **caractérisé en ce que** ledit contour d'interférence (18) est formé d'une crête et/ou d'un renfoncement dans la surface de positionnement courbe (14).

4. Dispositif d'essai de comprimés selon l'une quelconque des revendications 1 à 3, **caractérisé en ce qu'un** axe de rotation (19) du volet mobile (11) est agencé à un angle prédéfini ( $\alpha$ ) sur la surface de rupture fixe.

5. Dispositif d'essai de comprimés selon la revendication 4, **caractérisé en ce que** l'angle ( $\alpha$ ) est inférieur ou supérieur à  $90^\circ$ , de préférence d'environ  $80^\circ$  ou d'environ  $100^\circ$ .

6. Dispositif d'essai de comprimés selon l'une quelconque des revendications 1 à 5, **caractérisé en ce qu'**une surface de positionnement supplémentaire est formée sur la surface de rupture mobile (17).
7. Dispositif d'essai de comprimés selon la revendication 6, **caractérisé en ce que** la surface de mesure et/ou de rupture mobile (17) forme des parties d'un dispositif de mesure (13).
8. Dispositif d'essai de comprimés selon l'une quelconque des revendications précédentes, **caractérisé en ce que** sur le volet (11) au moins un contour de redirection (16) destiné à la redirection du mouvement de glisse d'un comprimé (12) est fourni.
9. Dispositif d'essai de comprimés selon l'une quelconque des revendications précédentes, **caractérisé en ce qu'**au moins un moyen de vibration (22) est fourni et conçu pour faire vibrer au moins le volet mobile (11).
10. Procédé de test de comprimés à l'aide d'un dispositif d'essai de comprimés selon l'une quelconque des revendications précédentes, **caractérisé en ce que** le comprimé (12) est initialement apporté à la station d'essai, placé sur la surface de positionnement (11) et, si nécessaire, orienté une première fois au moyen de la surface de positionnement (11), et ensuite déplacé au moyen de la surface de rupture mobile (17) de sorte qu'il est alors aligné en parallèle à la surface de rupture fixe (15), **en ce qu'**ensuite au moyen de dispositifs de mesure (13, 13a) des mesures de la largeur et/ou de la longueur et/ou de l'épaisseur sont réalisées sur le comprimé (12), **en ce qu'**au moyen d'un mouvement de pivot du volet mobile (11), est interrompu possiblement par le contour d'interférence (18) ou repositionné au moyen d'un dispositif de repositionnement (16) est alors apporté en une autre orientation et **en ce qu'**une mesure longitudinale du comprimé (12) peut alors possiblement être effectuée, après quoi un essai de résistance à la rupture ou un essai de comportement à la rupture est effectué par broyage du comprimé et le comprimé (12) est ensuite éliminé de la station d'essai en faisant pivoter au moins le volet mobile (11).
11. Procédé selon la revendication 10, **caractérisé en ce que** le volet mobile (11) pivote à partir d'une position horizontale maximale dans une position au-dessus de l'orientation horizontale du volet mobile (11), moyennant quoi l'orientation du comprimé (12) est tournée.
12. Procédé selon l'une quelconque des revendications 10 à 11, **caractérisé en ce qu'**au moins le volet mobile (11) est amené à vibrer par le moyen de vibration (22) destiné au positionnement du comprimé (12).
13. Procédé d'essai de comprimés à l'aide d'un dispositif d'essai de comprimés selon l'une quelconque des revendications 1 à 9 comprenant les étapes consistant à :
- 5  
apporter un comprimé (12) à une station d'essai ;  
10 placer le comprimé sur une surface de positionnement d'un volet mobile (11) dans la station d'essai ;  
faire pivoter le volet mobile (11) pour orienter le comprimé de manière sélective ;  
15 réaliser un essai de rupture sur le comprimé de manière à le broyer ; et  
faire pivoter le volet mobile (11) de manière à éliminer le comprimé (12) par gravité.
14. Procédé d'essai de comprimés tel que revendiqué selon la revendication 13, comprenant en outre l'étape consistant à : faire pivoter le volet (11) depuis une position horizontale vers une position au-dessus de l'horizontale de manière à faire tourner le comprimé.
15. Procédé d'essai de comprimés selon la revendication 13, comprenant en outre l'étape consistant à : faire vibrer le volet mobile (11) pour positionner un comprimé (12) de manière sélective.
- 20  
25  
30  
35  
40  
45  
50  
55

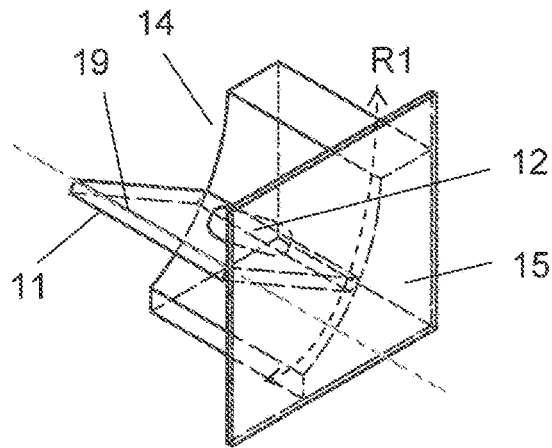

Fig. 1

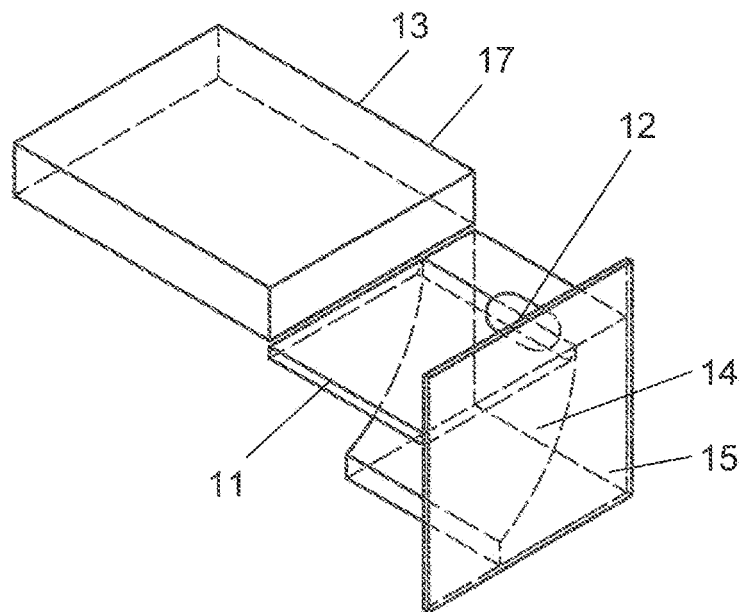

Fig. 2

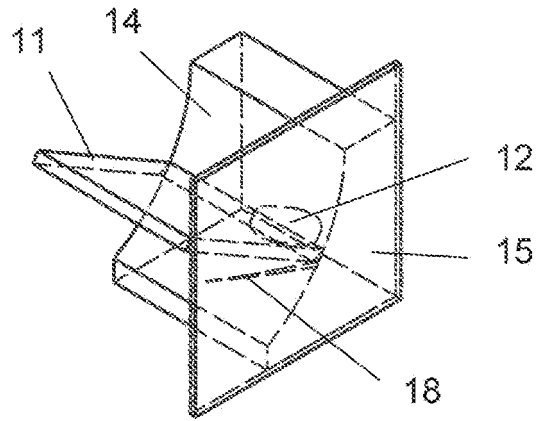

Fig. 3

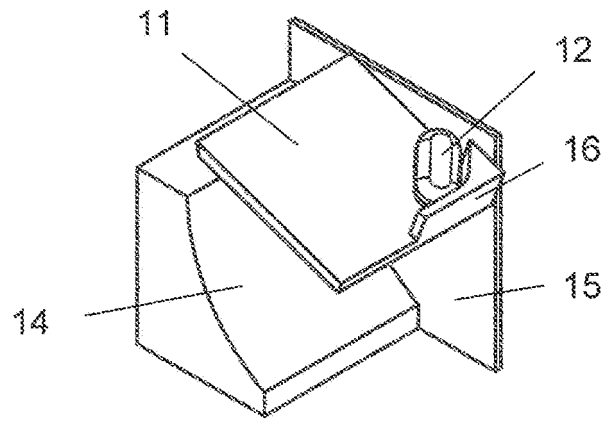

Fig. 4

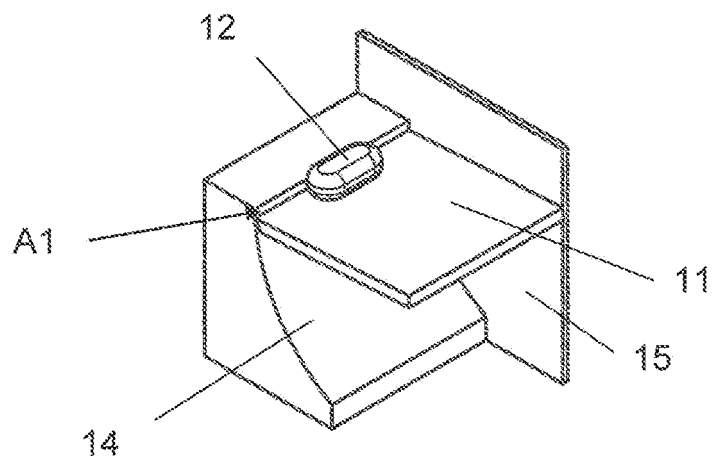

Fig. 5

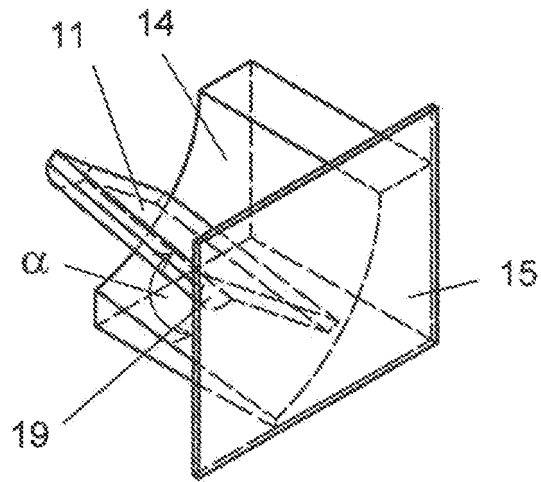

Fig. 6

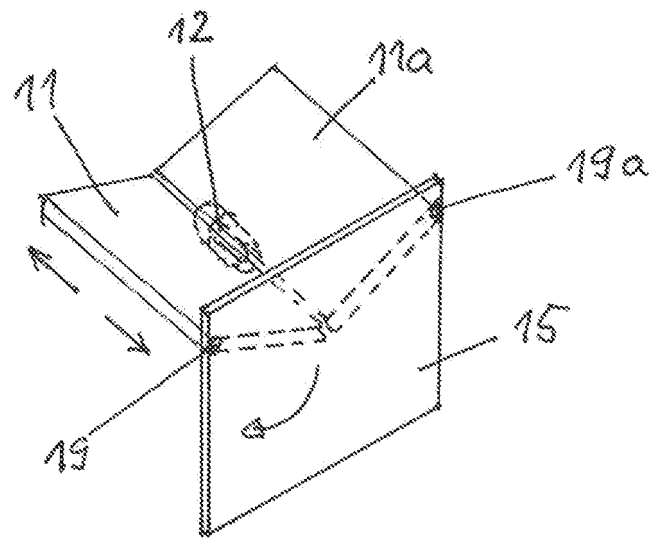

Fig. 7

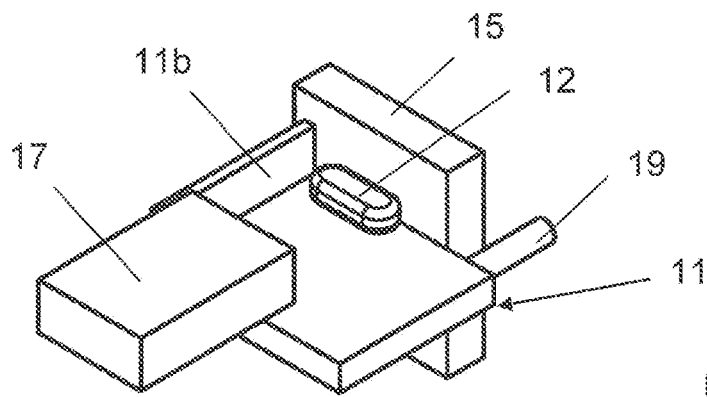

Fig. 8a

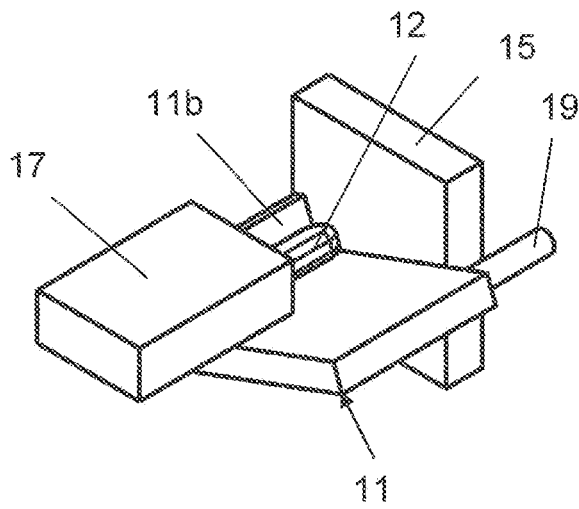

Fig. 8b

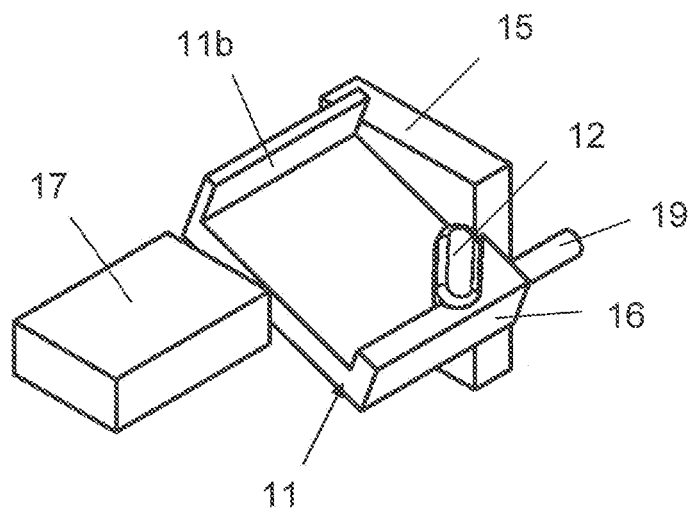
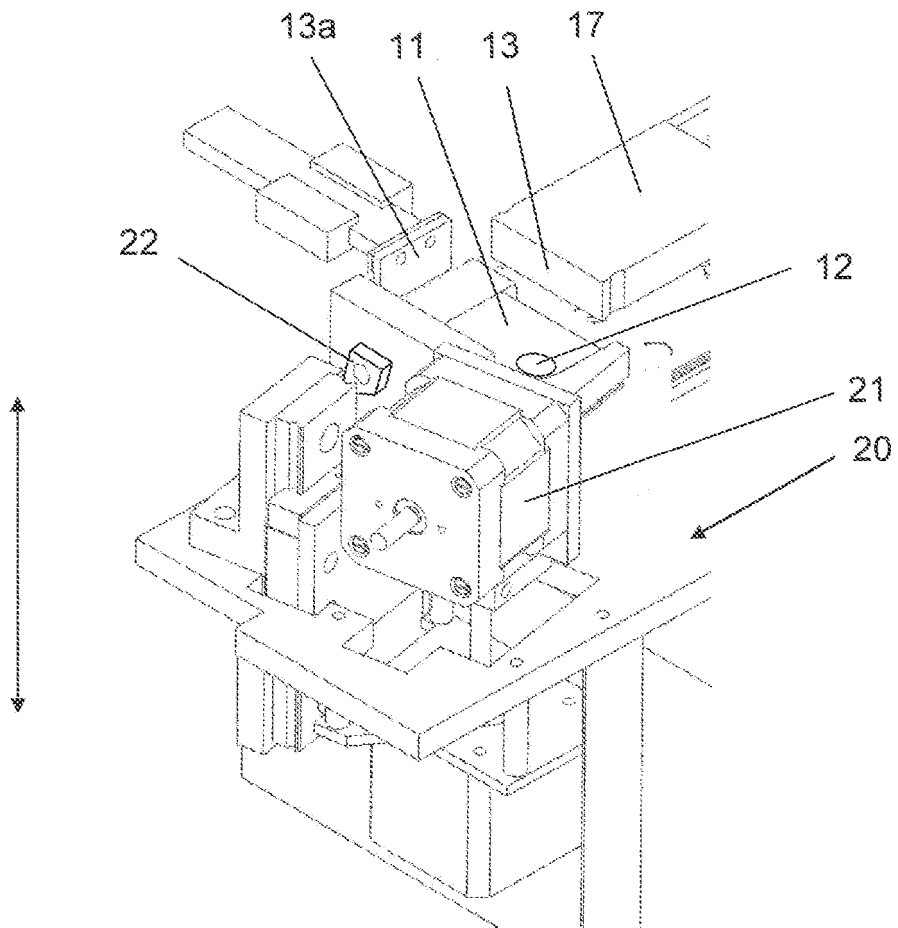
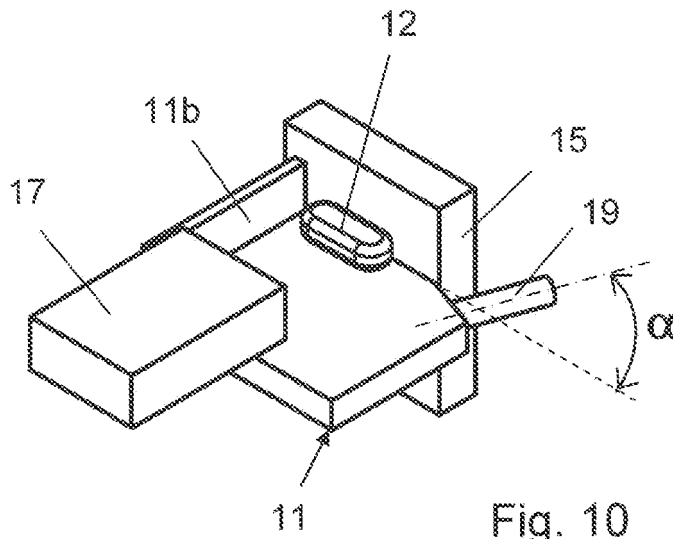

Fig. 9



**REFERENCES CITED IN THE DESCRIPTION**

*This list of references cited by the applicant is for the reader's convenience only. It does not form part of the European patent document. Even though great care has been taken in compiling the references, errors or omissions cannot be excluded and the EPO disclaims all liability in this regard.*

**Patent documents cited in the description**

- DE 102008035830 A1 **[0006]**
- DE 102004036777 A1 **[0007]**
- DE 102004059976 A1 **[0008]**
- DE 202008003673 U1 **[0010]**
- US 4472960 A **[0012]**
- JP 2001095897 A **[0013]**